

SE Encore Series Overhung Load and Thrust

OVERHUNG LOAD AND THRUST

Maximum Allowable Overhung Load

Overhung load (OHL) is a radial force imposed on the shaft of the reducer at a position beyond the outmost bearing. The values given in this catalog are the maximum allowable overhung load (or chain pull) capacity, in pounds, and are based upon the load being applied one shaft diameter from the oil seal face (max bore diameter for hollow shaft units). These values are independent of any other external forces (i.e. thrust) and are limited by the lesser of the bearing capacity or the shaft size. As speed increases above 2500 RPM, the bearing capacity decreases, reducing the overall OHL capacity. Additionally, the allowable overhung load will decrease as the center of the load gets farther from the speed reducer. This is discussed in detail under "Location of Overhung Loads." Contact Winsmith for OHL values of speed reducers with a bolt-on base (e.g. XDTS).

The bending moment capacity of the speed reducer, in pound-force inches (lbf-in), is determined by multiplying the OHL capacity by the distance from the bearing to the catalog OHL location l . See Table 2 for values of l .

Maximum Allowable Overhung Loads Based Upon Chain Pull

When a chain, gear, or belt drive is mounted to a reducer shaft, the OHL is estimated using the following equation:

$$\text{OHL} = \text{Transmitted Torque} / \text{Pitch Radius of the mounted member} \times \text{OHL Factor} \times \text{Service Factor}$$

This calculated value, in addition to the weight of the mounted member, must not exceed the allowable OHL capacity of the reducer. Overhung loads are subject to the same service factors that control the capacity of the reducer as well as the overhung load factors.

Overhung Load Factors

With a chain drive, the overhung load is equal to the torque divided by the radius of the sprocket because there is practically no pull on the loose side of the chain.

If an external gear or pinion is used, the overhung load is along the line of action and is greater than the load computed from the torque and pitch radius. In this case, AGMA recommends that the net overhung load derived from the torque and pitch radius of the gear be multiplied by an OHL factor of $1\frac{1}{4}$.

When a "V" belt sheave is specified, there is a pull on the loose side of the belt. In this case the sum of the pull on the tight side and on the loose side is the overhung load. AGMA recommends that the net overhung load derived from the torque be multiplied by an OHL factor of $1\frac{1}{2}$ to allow for this loose side tension.

A flat belt pulley requires a tension on the loose side to keep it tight. Therefore, AGMA recommends that the net overhung load derived from the torque be multiplied by an OHL factor of $2\frac{1}{2}$.

Variable speed drives, with a flat faced pulley on the reducer, and used with a "V" belt, derive their variability by changing the tension in the belt. In this case use an OHL factor of $2\frac{1}{2}$ to $3\frac{1}{2}$.

These factors are expressed in Table 1.

TABLE 1. OVERHUNG LOAD FACTORS

Type Of Load	Multiply The Actual Calculated OHL By:
Chain Sprocket	1
Gear or Pinion	1-1/4
"V" Belt	1-1/2
Flat Belt	2-1/2
Variable Speed Drive Pulley	3-1/2

Overhung Position and Direction Limitations

The overhung load capacities listed in this catalog may be used when the force from the chain pull is directed toward the base or applied parallel to the base on the near side of the sprocket as shown in Figure 1. These illustrations demonstrate the ideal chain pull conditions and should be used whenever possible.

When the force from the chain pull is directed away from the base or applied parallel to the base on the far side of the sprocket (as shown in Figure 2), it may be necessary to reduce the allowable overhung load capacity. Avoid these chain pull directions or contact Winsmith for assistance.

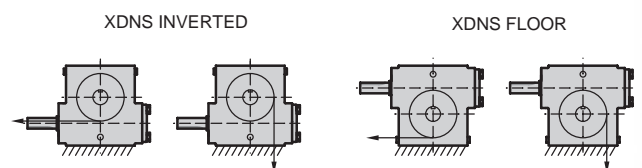

Figure 1.

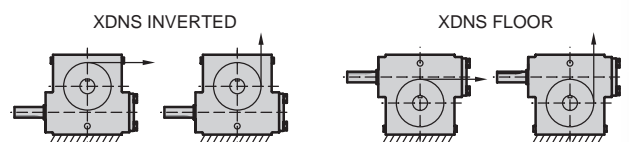

Figure 2.



SE Encore Series Overhung Load and Thrust

Location of Overhung Loads

In many cases, the center of the pulley, gear, or sprocket, which determines the location of the overhung load, does not coincide with the catalog position, "one shaft diameter from the seal face". If the location of the overhung load is outside this position, then the allowable overhung load (L_a) can be determined from the equation:

$$L_a = L_c \times \left(\frac{l}{l + \Delta l} \right)$$

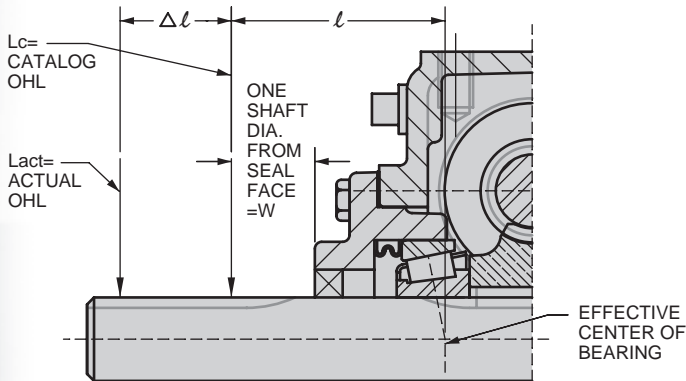

Where;

L_a = Allowable overhung load in pounds.

L_{act} = Actual overhung load.

L_c = Catalog rating of overhung load in pounds.

l = A factor given in Table 2 (This is the actual distance from the effective center of the bearing to the reference location for the catalog OHL capacity).

Δl = Distance from location of the actual overhung load to a point one shaft diameter from the seal face or housing.

Example:

An E30 XDNS reducer, with a gear ratio of 25:1, is subjected to a torque of 1500 lbf-in on the output shaft. The torque is transmitted through a chain sprocket of 3/4 pitch 23 teeth. The centerline of the sprocket is 5.00 inches from the center of the reducer. The service is 24 hours per day, uniform loading.

Data:

Service Factor = 1.25

Chain Overhung Load Factor = 1.0

Radius of 23 Tooth 3/4" Pitch Chain = $5.508"/2 = 2.754"$

Catalog Overhung Load = 1350 lbs

Catalog OHL Location from Center of Housing = $P - S + W = 5.88" - 2.88" + 1.375" = 4.375"$

(Where P, S and W are taken from the E30 XDNS reducer layout shown in another section of this catalog)

Actual OHL Location from Center of Housing = 5.00"

l (From Table 2) = 2.817"

$\Delta l = 5.00" - 4.375" = .625"$

Design Overhung Load = Torque/Radius x Service Factor x OHL Factor = $1500/2.754 \times 1.25 \times 1.00 = 680$ pounds

Allowable Overhung Load = $L_a = L_c \times l / (l + \Delta l) = 1350 \times 2.817 / (2.817 + .625) = 1105$ pounds

Since the allowable OHL (1105 lbf) exceeds the design OHL (680 lbf), the unit can support the load.

TABLE 2. VALUE OF "l" FOR SE ENCORE SPEED REDUCERS

Size	Solid Input Shaft			Output Shaft					
	SGL Reduction	DBL Reduction Worm-Worm	DBL Reduction Worm-Helical	Solid Output & Top Ext Vert. Output	Solid Output Bottom Ext Vert. Output	Hollow Output Except Drywell	Drop Bearing	Drywell Cover Side	Drywell Flange Side
E13	1.451			1.905	1.905				
E17	1.580	1.451		2.205	2.205	2.388			
E20	1.580	1.451		2.205	2.205	2.906			
E24	2.030	1.580	1.760	2.440	2.478	3.140			
E26	2.380	1.580	1.760	2.440	2.478	3.461	2.544		
E30	2.080	1.580	1.760	2.817	2.793	3.712	2.992	4.158	3.716
E35	2.980	1.580	1.760	3.303	3.303	4.103	3.312	4.715	3.914
E43	2.875	2.380	2.040	3.743	3.743	5.230	3.555	5.841	4.963

Maximum Allowable Thrust Load

The maximum allowable thrust load values (lbf) in this catalog assume that no simultaneous overhung load exists. Contact Winsmith if OHL and thrust loads exist simultaneously in the application.