

GENERAL INFORMATION

MODEL †	941	951	961	971	981
DSR SHIPPING WEIGHT	207	320	440	700	900
FDSR SHIPPING WEIGHT	211	325	445	706	908
CFDSR SHIPPING WEIGHT ††	238	355	476	736	938
CDSR SHIPPING WEIGHT ††	234	360	481	742	946
APPROX. OIL CAPACITY (QUARTS)	2.1	2.5	3.5	8	10

GEAR RATIO RANGE 5:1 THRU 100:1
DOUBLE REDUCTION VERSION

PAGE 68

†Weights are approximate and include shipping container.
††Add 20 pounds if adapter ring is furnished with motor adapter.

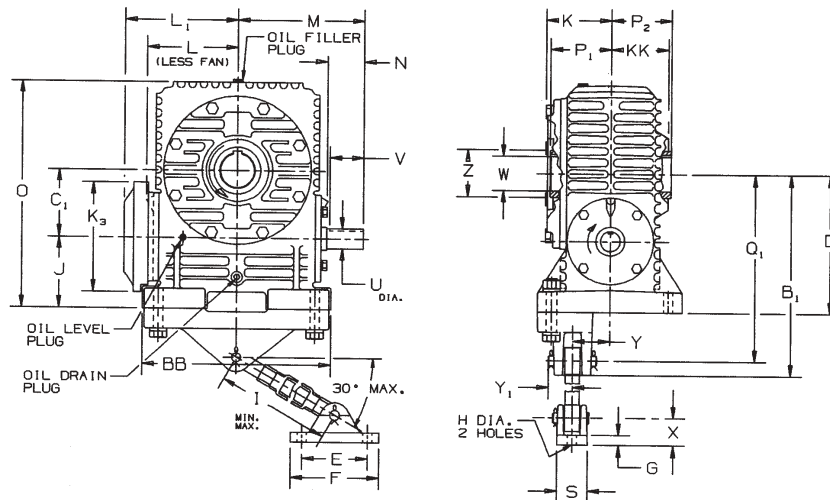
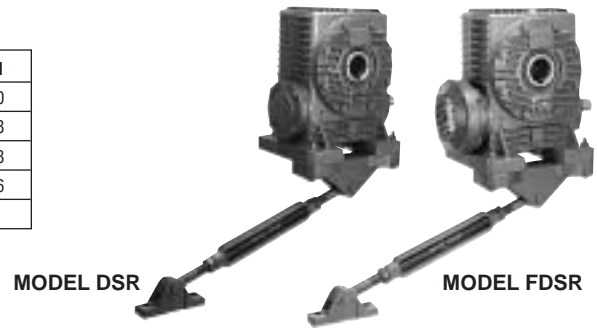

SIZE	BB	B ₁	C ₁	D	E	F	G	H	I _{MAX}	I _{MIN}	J	K	K ₃ DIA.	KK	L°	L ₁	M	O	P ₁	P ₂	Q ₁	S	X	Y	Y ₁	Z
941	12.76	13.94	3.937	9.69	3.50	4.75	.56	.53	29.00	21.00	5.75	4.34	7.88	4.00	5.78	7.81	9.00	15.69	4.25	4.25	12.94	2.13	1.63	2.25	1.44	4.13
951	15.29	15.43	4.921	10.67	5.00	6.75	.75	.81	31.00	22.00	5.75	4.81	7.88	4.81	6.77	8.56	9.73	17.56	5.06	5.06	14.30	2.06	1.94	2.88	1.94	4.88
961	16.58	17.66	5.906	12.16	5.75	7.75	.88	.94	37.50	26.50	6.25	5.70	9.63	5.06	8.47	10.69	11.10	19.91	5.31	5.31	16.41	2.69	2.38	3.25	2.19	5.75
971	19.40	21.27	6.890	14.77	5.75	7.75	.88	.94	37.50	26.50	7.88	6.56	10.75	6.44	9.39	12.22	13.25	23.88	6.69	6.69	20.02	2.69	2.38	3.88	2.44	6.75
981	22.19	24.25	7.874	16.37	5.75	7.75	.88	.94	37.50	26.50	8.50	6.88	11.50	6.13	10.45	12.69	15.50	26.50	6.30	6.30	23.00	2.69	2.38	4.25	2.63	6.75

SIZE	HIGH SPEED SHAFT			SLOW SPEED SHAFT BORES [□]				
	U°	N	V	KEYWAY	W [△]	KEYWAY	W [△]	KEYWAY
941	1.500	3.22	3.25	3/8 x 3/16	2 7/16	3/8 x 3/16	2 15/16	5/8 x 5/16
951	1.500	3.00	3.06	3/8 x 3/16	2 5/8	3/8 x 3/16	3 1/16	7/8 x 7/16
961	1.750	3.17	3.12	3/8 x 3/16	3	3/4 x 3/8	3 15/16	1 x 3/8
971	1.750	4.25	4.25	3/8 x 3/16	3 3/4	3/4 x 3/8	4 1/16	1 x 1/2
981	2.000	5.60	5.47	1/2 x 1/4	3 3/4	7/8 x 7/16	4 1/16	1 x 1/2

° Shaft diameter tolerance +.000, -.001.
△ Bore tolerance +.000, +.002.
° Distance to high speed cap on units without a fan. (DSF)
□ Check with factory for other bore sizes.

SHAFT ARRANGEMENTS AND RELATIVE SHAFT ROTATIONS

DSR/FDSR Models

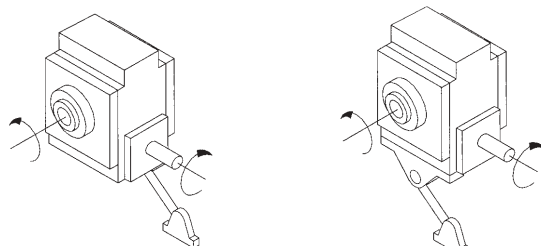

ASSEMBLY DR
STANDARD

ASSEMBLY DL
STANDARD

CDSR/CFDSR Models

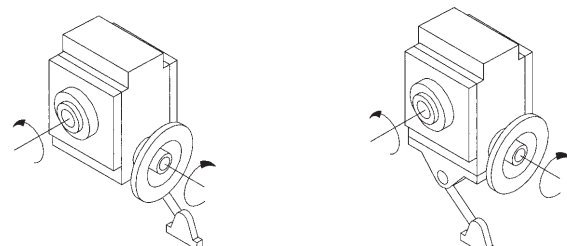

ASSEMBLY DR
STANDARD

ASSEMBLY DL
STANDARD

The input shaft may be driven in either direction.



D-90[®] TYPE DE[®]

CDSR/CFDSR

MODEL CDSR



MODEL CFDSR

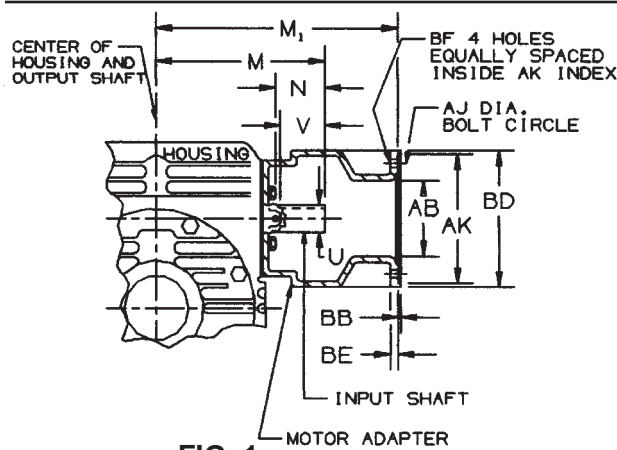

FIG. 1

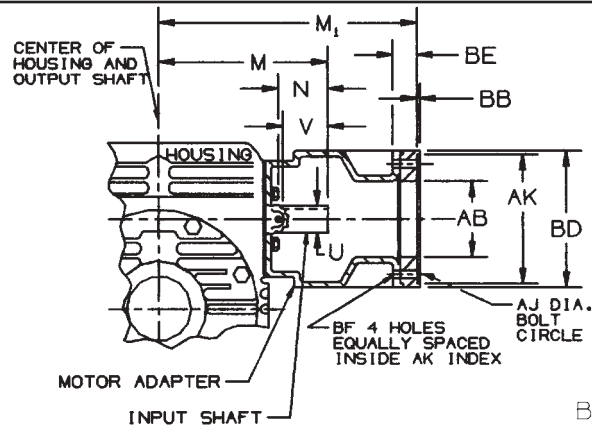

FIG. 2

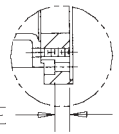

FIG. 3

UNIT SIZE	N.E.M.A. FRAME SIZE	OBSOLETE N.E.M.A. FRAME SIZE	AB	AJ	AK	BB	BD	BE	BF	U	N	V	M	M ₁	KEYWAY	CONFIGURATION
941	182TC-184TC	213C-215C	5.00	7.25	8.5005 / 8.5025	.19	9.00	.50	.53	1.500	2.63	3.25	9.00	13.00	3/8 x 3/16	FIGURE 1
	213TC-215TC		5.00	7.25	8.5005 / 8.5025	.19	9.00	.50	.53	1.500	2.63	3.25	9.00	13.00	3/8 x 3/16	FIGURE 1
	254TC-256TC	254UC-256UC	5.00	7.25	8.5005 / 8.5025	.19	9.00	1.44	.53	1.500	2.63	3.25	9.00	13.94	3/8 x 3/16	FIGURE 2*
951	182TC-184TC	213C-215C	5.00	7.25	8.5005 / 8.5025	.19	9.00	.50	.53	1.500	2.93	3.06	9.73	13.75	3/8 x 3/16	FIGURE 1
	213TC-215TC		5.00	7.25	8.5005 / 8.5025	.19	9.00	.50	.53	1.500	2.93	3.06	9.73	13.75	3/8 x 3/16	FIGURE 1
	254TC-256TC	254UC-256UC	5.00	7.25	8.5005 / 8.5025	.19	9.00	1.44	.53	1.500	2.93	3.06	9.73	14.69	3/8 x 3/16	FIGURE 2*
	284TC-286TC	284UC-286UC	5.00	9.00	10.5005 / 10.5025	.19	11.00	.81	.53	1.500	2.93	3.06	9.73	15.44	3/8 x 3/16	FIGURE 3*
961	213TC-215TC		5.00	7.25	8.5005 / 8.5025	.19	9.00	.50	.53	1.750	3.05	3.12	11.10	15.88	3/8 x 3/16	FIGURE 1
	254TC-256TC	254UC-256UC	5.00	7.25	8.5005 / 8.5025	.19	9.00	.50	.53	1.750	3.05	3.12	11.10	15.88	3/8 x 3/16	FIGURE 1
	284TC-286TC	284UC-286UC	5.00	9.00	10.5005 / 10.5025	.19	11.00	.25	.53	1.750	3.05	3.12	11.10	17.00	3/8 x 3/16	FIGURE 3*
971	213TC-215TC		5.00	7.25	8.5005 / 8.5025	.19	9.00	.50	.53	1.750	3.77	3.63	12.63	16.88	3/8 x 3/16	FIGURE 1
	254TC-256TC	254UC-256UC	5.00	7.25	8.5005 / 8.5025	.19	9.00	.50	.53	1.750	3.27	3.13	12.13	16.88	3/8 x 3/16	FIGURE 1
		284UC-286UC	5.00	9.00	10.5005 / 10.5025	.19	11.00	.81	.53	1.750	3.77	3.63	12.63	18.56	3/8 x 3/16	FIGURE 3*
	284TC-286TC		5.00	9.00	10.5005 / 10.5025	.19	11.00	.25	.53	1.750	3.77	3.63	12.63	18.00	3/8 x 3/16	FIGURE 3*
981	213TC-215TC		5.00	7.25	8.5005 / 8.5025	.19	9.00	.50	.53	2.000	3.66	3.47	13.50	17.88	1/2 x 1/4	FIGURE 1
	254TC-256TC	254UC-256UC	5.00	7.25	8.5005 / 8.5025	.19	9.00	.50	.53	2.000	3.29	3.09	13.13	17.88	1/2 x 1/4	FIGURE 1
		284UC-286UC	5.00	9.00	10.5005 / 10.5025	.19	11.00	.50	.53	2.000	3.29	3.09	13.13	19.00	1/2 x 1/4	FIGURE 3*
	284TC-286TC		5.00	9.00	10.5005 / 10.5025	.19	11.00	.50	.53	2.000	3.66	3.47	13.50	19.00	1/2 x 1/4	FIGURE 3*

*Adapter ring furnished with motor adapter.

L-SERIES LOVEJOY COUPLING SELECTION VS. FRAME SIZE (Coupling not provided with unit.)

UNIT SIZE	FRAME						
	182TC-184TC	213C-215C	213TC-215TC	254UC-256UC	254TC-256TC	284UC-286UC	284TC-286TC
941	L-110	L-110	L-110	L-110	L-150	—	—
951	L-110	L-110	L-110	L-110	L-150	L-150	L-190
961	L-150	L-150	L-150	L-150	L-150	L-190	L-190
971	—	L-150	L-150	L-150	L-150	L-190	L-190
981	—	L-190	L-190	L-190	L-190	L-190	L-190

If coupling selection differs from chart, input and/or motor shaft may need alteration.