



## Winsmith RD Output Flange

FOR USE WITH SOLID AND HOLLOW OUTPUT SHAFT SPEED REDUCERS

RECOMMENDED TORQUE VALUES FOR FASTENERS

CENTER DISTANCE (in.)	FASTENER SIZE (in.)	TIGHTENING TORQUE (lbf-in.)
1.75 - 3.00	3/8 - 16 x 1	335 - 400

Output Flange

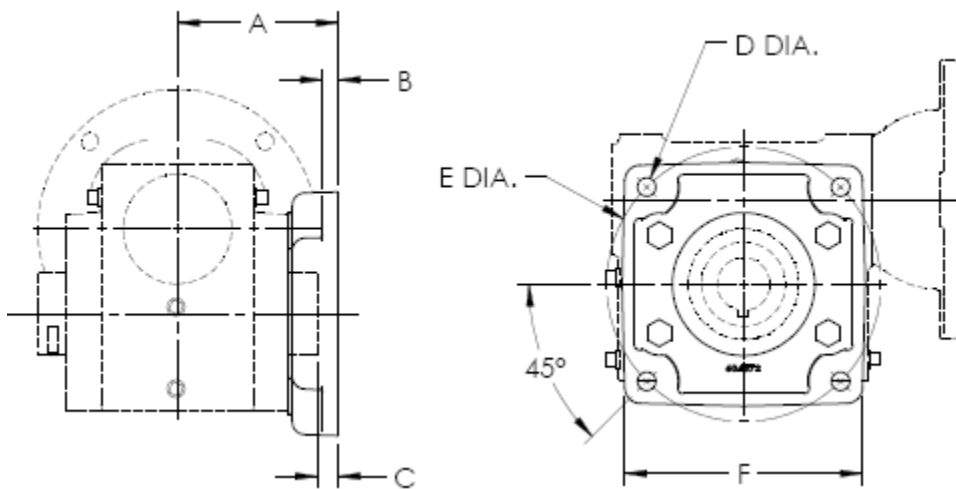

Output flange may also be used on solid output shaft reducers.

CD	A	B	C	D	E	F	Weight-lbs.	Kit #
1.33	2.50	0.31	N.A	0.38	5.00	4.33	2	152050
1.75	3.63	0.38	0.50	0.44	5.88	5.13	2	152029
2.00	3.81	0.38	0.50	0.44	6.50	5.77	3	152030
2.38	3.94	0.38	0.50	0.44	7.50	6.81	4	152031
2.63	4.00	0.38	0.50	0.44	8.00	7.56	5	152032
3.00	4.22	0.50	0.53	0.56	9.00	8.20	6	152033



## Warnings

Winsmith products, and associated equipment and machinery, are intended for selection and use by trained and skilled persons capable of determining their suitability for the specific application or use. Proper selection, installation, operation and maintenance, including implementation of adequate safety precautions, are the responsibility of the purchaser or user. The following safety precautions, as well as additional safety precautions that may be required for the specific application or use, are the responsibility of the purchaser or user. FAILURE TO OBSERVE REQUIRED SAFETY PRECAUTIONS COULD RESULT IN SERIOUS INJURY TO PERSONS OR PROPERTY OR OTHER LOSS.

## Lock-out/Tag-out

It is EXTREMELY IMPORTANT that equipment or machinery does not unexpectedly start. To prevent this possibility, all electrical or other input power sources must be turned off, and properly locked out. Tag out procedures must be followed before working on or near the reducer or any associated equipment. Loads on the input and output shafts should be disconnected prior to working on any reducer. Failure to observe these precautions may result in serious bodily injury and/or property damage.

## Grounding

Be sure the reducer and associated equipment are properly grounded and otherwise installed in accordance with all electrical code requirements.

## Protective Guarding / Loose Clothing, etc.

Always insure there is proper protective guarding over all rotating or moving parts. Never allow loose clothing, hair, jewelry and the like to be worn in the vicinity of rotating or moving parts or machinery. The purchaser or user is responsible for complying with all applicable safety codes. Failure to do so may result in serious bodily injury and/or damage to property or other loss.

## Selection & Installation

This speed reducer and associated equipment must be selected, installed, adjusted and maintained by qualified personnel who are knowledgeable regarding all equipment in the system and the potential hazards involved.

## Consult Catalog Ratings

Load, torque and other requirements must not exceed the published ratings in the current catalog and/or on the speed reducer nameplate. The reducer selected must be consistent with all service factors for the application. See Winsmith catalogs and [www.winsmith.com](http://www.winsmith.com).

## Brake Torque Loads

Whenever a brake or any other stopping force is involved in an application, braking torque loads imposed on the speed reducer must not exceed the allowable load ratings.

## Not a Brake

Speed reducers should never be used to provide the function of a fail safe brake or an assured self locking device. Speed reducers must never be used to replace a brake or a critical braking application function.

## Excess Overhung Loads

Excessive overhung loads on the input or output shafts of a speed reducer may cause premature fatigue failures of the bearings and/or shafts. Mount gears, pulleys and sprockets as close to the housing as possible to minimize such loads. Do not exceed catalog ratings.

## Excess Thrust Loads

Excessive thrust loads on the input or output shafts of a gear reducer may cause premature failure of bearings. Do not exceed catalog ratings.

## Alignment

Properly align any input and output power transfer elements connected to the speed reducer. Even slight misalignments in a rigid mounting system may cause binding, large vibration forces or excessive overhung loads, leading to premature bearing, shaft, or speed reducer failure. Use of flexible couplings that allow the reducer and connected transfer

elements to self-align during operation will compensate for minor misalignments.

## Not a Support Structure

A speed reducer must never be used as an integral component of a machine superstructure or support frame that would subject it to additional loads other than properly rated loads transmitted through the shafts.

## Mounting Position

The speed reducer should be mounted in one of the mounting positions shown in the catalog. Different mounting positions should not be used without contacting Winsmith as this may result in improper lubrication.

## Overhead Mounting

Mounting of a speed reducer in overhead positions may be hazardous. Use of external support rails or structure is strongly recommended for any over-head mounting.

## Lifting Eyebolts

Any lifting supports or eyebolts provided on the speed reducer are supplied with the purpose of vertically lifting only the speed reducer, without any other attachments or motors. Inspect such supports and bolts before each use.

## Properly Secure Mounting Bolts

Proper mounting bolts and proper torques must be applied and maintained to insure the speed reducer is securely mounted to the desired machinery. Inspect regularly as machine vibration may loosen fasteners.

## Thread Locking Compound

Proper thread locking compound should be appropriately applied to the cleaned threads of all mounting bolts connecting or securing the speed reducer to equipment and any drive, accessories, or brake components attached to the speed reducer. If, at any time after installation a factory supplied assembly or construction bolt is removed, care must be taken to thoroughly clean off the old thread locking compound and a new appropriate thread locking compound must be applied. Failure to properly apply new thread locking compound on all mounting or reducer construction bolts may result in serious injury or death from falling mechanical components.

## Reducer Surface Is Hot

Operating speed reducers generate heat. Surface temperatures may become hot enough to cause severe burns. Proper personal protective equipment should be used.

## Noise

Operating speed reducers may generate high noise levels. Use appropriate hearing protection and avoid extended exposure to high noise levels.

## Lubricants Hot and Under Pressure

The temperature of lubricants inside a speed reducer may be very high. The reducer should be allowed to cool to ambient temperature before removal of any vent, drain, level, or fill plugs, and before removing seals or bearing covers. Speed reducers without a pressure vent may also be under great internal pressure. Slowly loosen the lubricant fill plug above the lubricant level to vent any internal pressure before further disassembling.

## Lubricant Contact

Contact with lubricants can present safety concerns. Proper personal protective equipment should be used whenever handling speed reducer lubricants. Consult the lubricant MSDS sheet which is often available on the lubrication manufacturer's website.

## FDA, USDA, and NSF Applications

Factory supplied lubricants may not be suitable or safe for applications involving food, drugs and similar products. This includes applications subject to FDA, USDA, NSF or other regulatory jurisdiction. Consult the lubricant supplier or Winsmith for acceptable lubricants.

## Inspection and Lubrication

Ensure proper operation by regularly inspecting the speed reducer and following all maintenance, operation and lubrication guidelines.

HBD Industries, Inc. and its subsidiaries cannot accept responsibility for possible errors in catalogues, brochures, other printed materials, and website information, and may change, delete, add to or otherwise modify such information without notice. HBD reserves the right to alter its products without notice, including products already on order, provided that such alteration can be made without changes being necessary in specifications already agreed to. All trademarks in this material are the property of the HBD Industries, Inc., or its subsidiaries. The HBD and HBD brands logotype, are trademarks of HBD Industries, Inc. All rights reserved.

PEERLESS- WINSMITH, INC.  
172 EATON STREET  
SPRINGVILLE, NY  
14141-1197 USA  
TEL: 1 (716) 592-9310  
FAX: 1 (716) 592-9546  
[www.winsmith.com](http://www.winsmith.com)